

INTV[®] System III

MASTER COMPONENT OWNER'S MANUAL

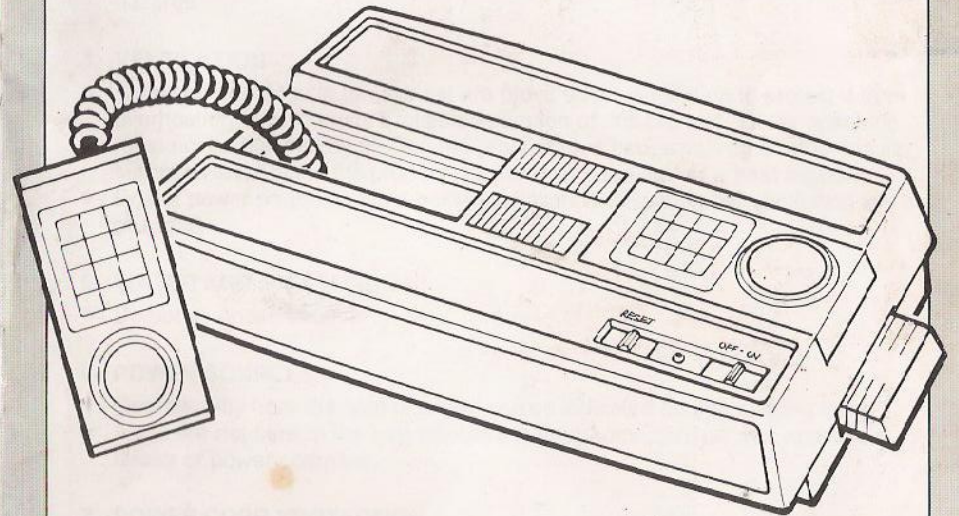

FOR COLOUR TV VIEWING ONLY

IMPORTANT SAFETY INSTRUCTIONS

INTV SYSTEM III OWNER

READ INSTRUCTIONS

All safety and operating instructions should be read before operating this appliance.

HEED THE WARNINGS

All warnings on this appliance and in the operating instructions should be adhered to.

1. FOLLOW INSTRUCTIONS

- All operating and use instructions should be followed.

2. CLEANING

- Unplug the unit from the wall outlet before cleaning.
- Do not use liquid cleaners or aerosol cleaners. Use a damp cloth for cleaning.

3. ATTACHMENTS

- Do not use attachments not recommended by the INTV as they may cause hazards.

4. VENTILATION

- Slots and openings in the cabinet are provided for ventilation to protect it from overheating, and to ensure reliable operation of this product. These openings must not be blocked by placing the product on a bed, sofa, rug or other similar surface. Never place the product near or over a radiator or a heat register.
- Do not power on the unit in a built-in installation unless proper ventilation is provided.

5. WATER AND MOISTURE

- Do not use near water.

6. POWER SOURCES

- Operate only from the type of power source indicated on the marking label.
- If you are not sure of the type of power in your home consult your appliance dealer or power company.

7. POWER CORD PROTECTION

- Power supply cords should be routed so that they are not likely to be walked on or pinched, paying particular attention to the cords at plugs, convenience receptacles, and the point where they exit from the appliance.

SAFE THESE INSTRUCTIONS.

OPEN THE CARTON AND YOU WILL FIND THESE PARTS:

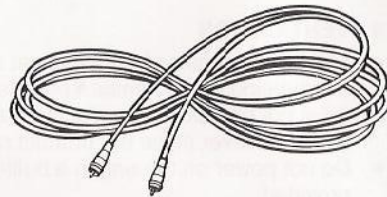
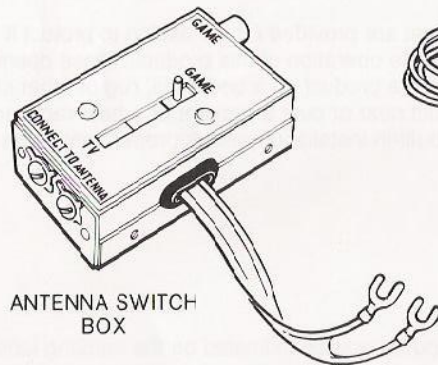
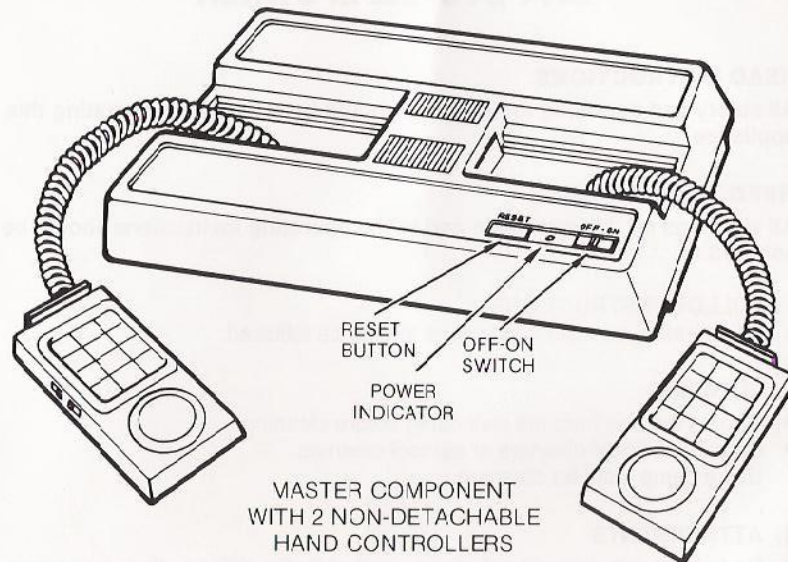

Warning: This equipment has been certified to comply with the limits for a Class B computing device pursuant to Subpart J of Part 15 of FCC rules. Only peripherals (computer input/output devices, terminals, printers,

etc.) certified to comply with the Class B limits may be attached to this computer. Operation with non-certified peripherals is likely to result in interference to radio and TV reception.

HOW TO CONNECT THE ANTENNA SWITCH BOX

The Antenna Switch Box enables you to use your television set for either regular television programming or with Intellivision. Once the Antenna Switch Box is installed, a flick of the switch allows you to make your choice.

CONNECTING THE SWITCH BOX IS EASY. JUST FOLLOW THESE SIMPLE STEPS:

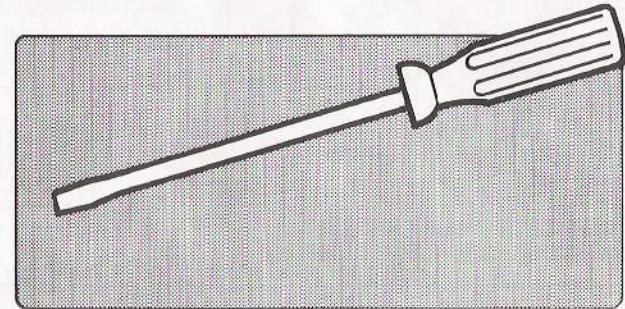

THE ONLY TOOL YOU WILL NEED IS A FLATHEAD SCREWDRIVER.

Disconnect the VHF twin lead antenna wire (if there is one) from your television set and connect it to the Antenna Switch Box.

Connect the twin lead wire from the Switch Box to the VHF screw terminals of your television set.

IMPORTANT!

If you disregard any of the following rules you may cause interference to nearby television sets.

- Never attach loose wires to your antenna terminals when you are using the Master Component.
- The Antenna Switch Box comes with its own twin lead wire. Never substitute a longer twin lead wire from the Switch Box to your television set.
- Do not attach the twin lead wire from the Switch Box to any television antenna or cable-TV outlet.

INTV Service number :

(213) 540-7390

FEEL FREE TO CALL IF YOU HAVE ANY QUESTIONS OR PROBLEMS WITH YOUR SYSTEM.

WHERE FLAT "TWIN LEAD" TYPE OF ANTENNA WIRE IS USED

CONNECT SWITCH BOX AS SHOWN.

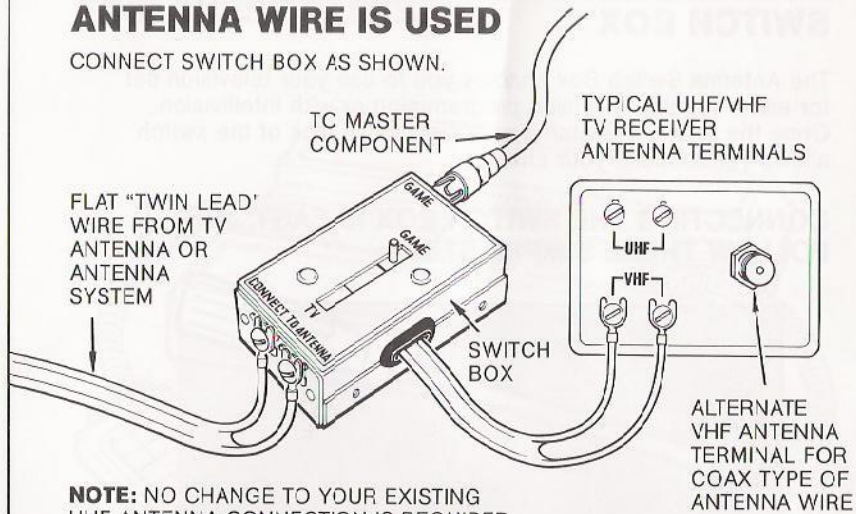

NOTE: NO CHANGE TO YOUR EXISTING UHF ANTENNA CONNECTION IS REQUIRED.

FOR TV INSTALLATIONS WHERE ROUND "COAX" TYPE OF ANTENNA WIRE IS USED

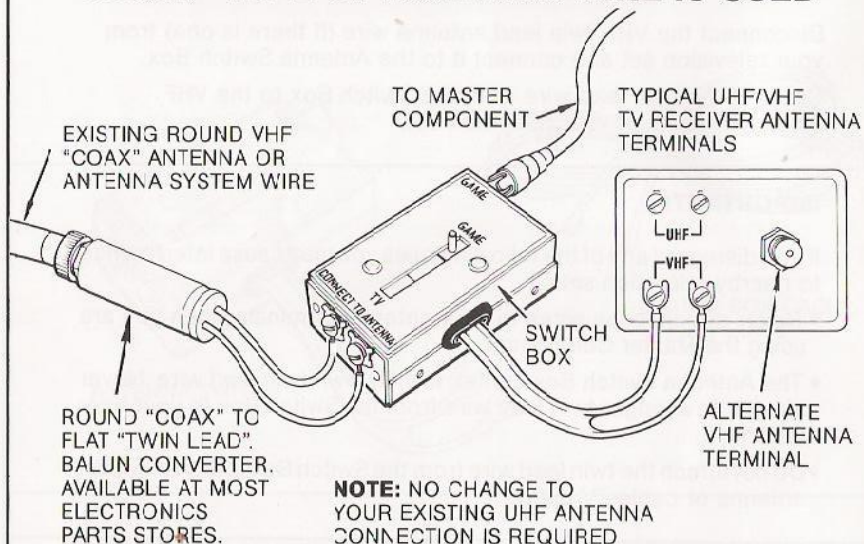

NOTE: FOLLOW THE DIRECTIONS IN YOUR TV OWNERS MANUAL OR ON THE BACK OF YOUR SET FOR CHOOSING BETWEEN THE ALTERNATE "COAX" VHF TERMINAL AND THE FLAT "TWIN LEAD" VHF SCREW TERMINALS. YOU MUST SELECT THE FLAT "TWIN LEAD" VHF SCREW TERMINALS WHEN USING THE SWITCH BOX.

SET UP YOUR MASTER COMPONENT

1

Connect the Switch Box cable to the Switch Box by plugging into socket marked GAME CORD. Plug other end of cable into the Master Component socket in the rear of the Master Component on the right hand side. It makes no difference which end goes where; cable is symmetrical.

Your Switch Box is equipped with an adhesive backing for installation on the back of your TV set. Simply peel off thin paper layer to expose adhesive surface and place firmly on desired mounting location.

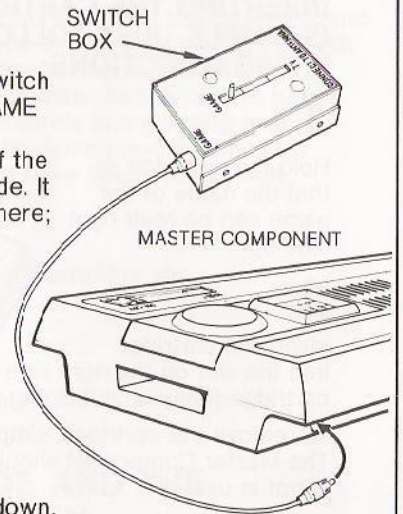

2

Turn the Master Component over, face down, and see switch labeled "CH 3 - CH 4." If channel 3 is a normal television station channel or cable channel in your area and channel 4 is not, then move the switch to channel 4. If channel 4 is a normal television station channel or cable channel in your area and channel 3 is not, move the switch to channel 3. If both channels 3 and 4 are normal television station channels or cable channels in your area, move the switch to the channel with the weaker reception. (If you receive channel 3 better than channel 4, move switch to channel 4 and vice versa.)

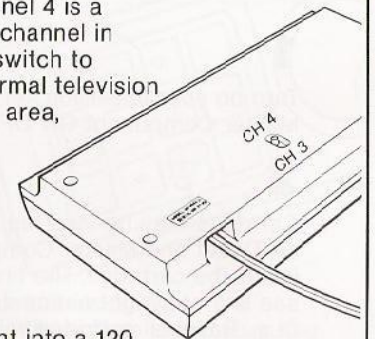

3

Plug the wall plug of the Master Component into a 120 volt wall outlet. The Master Component plug will not fit a 220 volt outlet.

4

Set the Antenna Switch Box at GAME.

5

Turn on your television set.

6

Turn your television set to either channel 3 or 4, depending on where you set the Master Component switch in Step 2. If Master Component switch is set on CH 3, turn TV set to channel 3. If Master Component switch is set on CH 4, turn TV set to channel 4.

HOW TO INSERT THE CARTRIDGE

INSERTING THE CARTRIDGE IS SIMPLE. JUST FOLLOW THESE DIRECTIONS:

1

Hold the cartridge so that the name of the game can be read right side up.

2

Insert the cartridge into the slot on the right side of the Master Component. Insert the cartridge firmly until it is engaged, but do not force it.

To remove the cartridge, simply pull it straight out of the slot. The Master Component should be turned to OFF when the System is not in use.

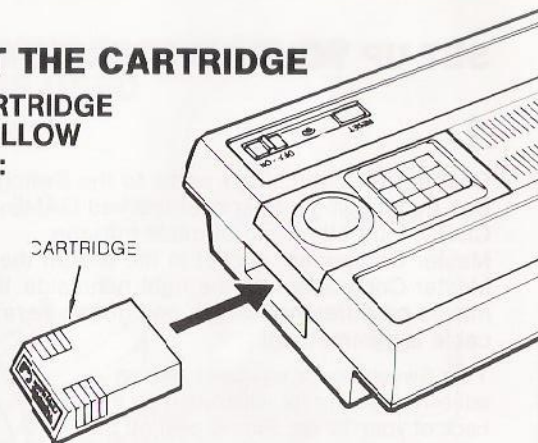

HOW TO USE THE MASTER COMPONENT

1

Turn on your television set and slide the Master Component ON-OFF switch to ON.

2

Cartridge may be inserted prior to turning on TV set and Master Component. If not, insert the cartridge. The first thing you will see is a copyright notice and game title. (e.g., Baseball cartridge will show game, title and date of copyright.)

NOTE: If no playfield appears on your television screen or if a non-rational sequence of information appears on the screen, check to be sure that the cartridge is inserted properly, that the power is on and that all connections are properly made. If everything is correct, merely push the RESET button on top of Master Component. This will remedy the situation. What has happened is that the game program has been picked up at the wrong point. Pushing the RESET button gets the computer started at the beginning.

3

Adjust fine tuning control on channel 3 or channel 4 of television. If it is not normally used, it is likely to be badly out of adjustment.

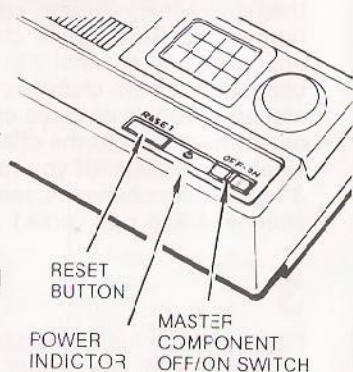

4

Adjust the television VHF fine tuning control to best picture and sound. If your set has automatic fine tuning you should operate your TV with automatic fine tune on. If difficulty in fine tuning is encountered, try tuning in the game channel with the automatic tuning feature turned off. Adjust volume, picture and color controls to a pleasing level. A gradual discoloring of white areas in the game playfield indicates that the brightness or contrast controls have been set too high.

5

Follow the instruction book for individual cartridge you are using.

6

If at any point in the game you wish to start over, simply press the RESET button.

THE INTERMISSION CODE AND THE AUTOMATIC BLANK SCREEN

If for any reason you wish to interrupt your game, use the Intermission Code on your Hand Controller. Merely depress keys 1 and 9 *simultaneously* on either one of the Hand Controllers. This will cause the television screen to go blank and will freeze the game at the point you left it. To resume the game, just push any key on either Hand Controller and the game will begin again where you left off.

DEPRESS KEYS 1 AND 9

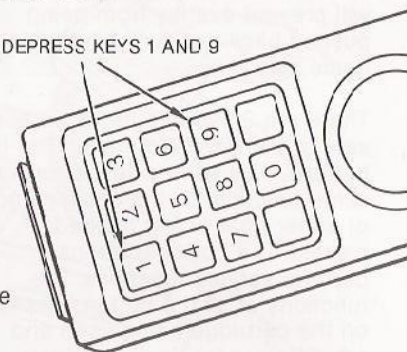

If you leave the game without using the Intermission Code, the Master Component will automatically turn the screen blank after five minutes. To turn the screen on again, you simply press any key on either Hand Controller. The purpose of this unique feature is to eliminate the possibility of a permanent playfield image being imprinted on your television screen.

HOW TO RETURN YOUR TELEVISION SET TO REGULAR PROGRAMMING

1

Slide the POWER switch on the Master Component to OFF.

2

Slide the switch on the Antenna Switch Box from GAME to TV.

THE HAND CONTROLLERS

The Master Component contains two Hand Controllers which are permanently attached with coil cables.

Since the Hand Controllers are crucial to any game you play, hold the Hand Controller in your hand before you begin play, just to get the feel of it.

You will notice that there are 12 keys on the keypad. These are used for feeding data into the computer.

With each cartridge there are 2 overlays which fit over the keypads of the 2 Hand Controllers. These overlays are keyed to the particular game being played and determine how the keys on the keypad relate to the cartridge. Slip the overlay under the keypad frame as shown. The lip at the top of the controller will prevent overlay from being pushed back out during normal game play.

There are 2 action buttons on each side of the Hand Controller. The top buttons, 1 on each side, perform the same function for the convenience of either right or left handed players. The bottom buttons perform varying functions. The functions of all the buttons depend on the cartridge being used and are different for each cartridge overlay.

The disc at the base of the Hand Controller is a directional control for those cartridges in which direction is a factor. *There are 16 directions on the disc. Direction of disc corresponds to direction on television screen. UP on the disc (toward the keypad) is UP on the screen, etc. For further instructions refer to your cartridge instructions.*

To operate the directional disc, press your finger on the outer edge and slide your finger around the edge to change direction of object you are moving. You have the ability to move



the object in any direction you wish. To stop motion, simply stop pressing disc. You must be pressing on the disc in some direction for motion to take place.

The keypad buttons and directional disc cannot be operated simultaneously. However, the action buttons and directional disc can be. See cartridge instructions.

When returning the Hand Controller to the Master Component, coil the cable beneath it in the cradle.

To avoid permanently overstretching the coiled cables, they should not be pulled out to their extreme length.

HOW TO TAKE CARE OF YOUR MASTER COMPONENT

The INTV SYSTEM III Master Component will bring you many years of fun and excitement if you follow a few simple rules to keep it in good condition. Read the following points carefully. They will help you get the maximum use from your Master Component.

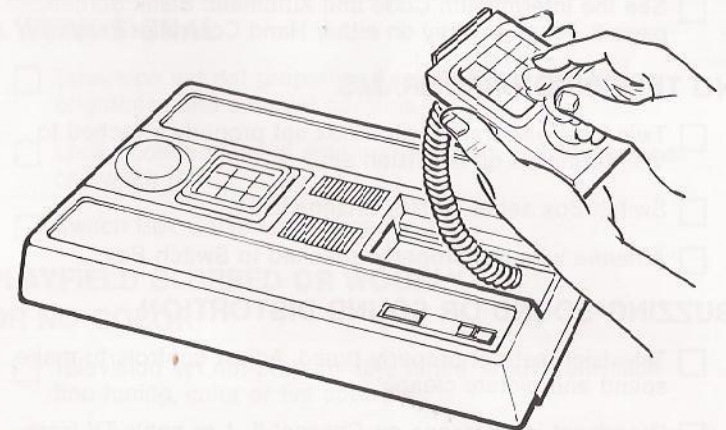

Do not force the cartridge into the component slot.

INTV Game cartridges are designed to prohibit hand contact with their electronic circuitry. However, care should be taken not to get the fingers into the open end of the cartridge. Static electricity, such as the kind you get from a rug, could damage the sensitive electronic components in the cartridge.

Turn the Master Component OFF when not in use.

If the Master Component is not to be used for a length of time the Switch Box Cable may be unplugged and stored behind TV while the AC power cord may be pushed inside of Master Component.

Handle the Master Component carefully. Do not drop the cartridges, component or Hand Controllers.

Do not lift the Master Component or the Hand Controllers by the wires, as serious damage can result.

Avoid exposing the cartridges, Master Component or Hand Controllers to excessive heat.

Do not set large objects which would block ventilation openings on top of Master Component housing.

Do not spill liquids onto the cartridges, Master Component or Hand Controllers.

Clean the exterior of your Master Component with a soft, *slightly* dampened cloth, BUT ONLY AFTER YOU HAVE TURNED THE POWER SWITCH TO "OFF" AND DISCONNECTED THE POWER CORD FROM THE 120 VOLT WALL OUTLET.

NOTE: It is normal for the top of Master Component to become warm during operation. The lower left corner of the Master Component will be slightly warm even when the Master Component On-Off switch is in the OFF position.

TROUBLESHOOTING CHECKLIST

SCREEN IS BLANK

- See the Intermission Code and Automatic Blank Screen, page 6. Press any key on either Hand Controller keypad.

NO TELEVISION PROGRAMS

- Twin lead wire from Switch Box not properly attached to VHF terminals on television set.
- Switch Box set at GAME. Change to TV.
- Antenna wire not properly attached to Switch Box.

BUZZING SOUND OR SOUND DISTORTION

- Television set not properly tuned. Adjust controls to make sound and picture clear.
- Broadcast interference on Channel 3, 4 or cable TV from an especially strong television station in your area. Disconnect the TV - VHF antenna wires from the Switch Box and continue playing, but you will have to reconnect again for TV viewing.

NO GAME SOUND EFFECTS

- Volume control on television set turned down. Turn it up.
- TV not fine tuned properly.

NO PLAYFIELD IMAGE OR WHITE-GREY SCREEN

- Cartridge not properly inserted in slot

- Check all connections; make sure power plug is plugged into outlet and that outlet has not been turned off by wall switch.
- Make sure you are tuned to correct channel, either Channel 3 or 4.
- Antenna Switch Box set at TV, change to GAME.
- Cable not properly plugged into Switch Box.
- Master Component power switch not turned on.
- Twin lead wire from Switch Box not properly attached to VHF terminals on television set.

EITHER SIDE OF PLAYFIELD NOT VISIBLE ON SCREEN

- Adjust the horizontal hold control on your television set.

PLAYFIELD INDISTINCT, RESEMBLING A WEAK SIGNAL

- Television set not properly adjusted. Adjust fine tuning, brightness and contrast controls.
- Loose connections at antenna terminals of television set or Switch Box.
- Switch Box Cable not plugged in fully.

PLAYFIELD BLURRED OR WOBBLY OR NO COLOR

- Television set not properly fine tuned. Adjust television fine tuning, color or tint controls.
- Broadcasting on Channel 3, 4 or cable TV by an especially strong television station in your area. Disconnect TV - VHF antenna wires from the Switch Box. Reconnect to watch regular TV.

INTV CORPORATION

LOS ANGELES: 21535 Hawthorne Blvd., Suite 223 • Torrance, CA 90503

NOTE: If Master Component malfunctions after all troubleshooting steps have been taken, disconnect and determine if television set is functioning properly. If so, consult your Master Component Limited Warranty for repair information.

60-DAY LIMITED WARRANTY

INTV Corporation warrants to the original consumer purchaser of its INTV System III in the United States that the product will be free of defects in material or workmanship for 60 days from the date of purchase under normal in-home use.

During the warranty period INTV Corporation will, at its option, repair or replace the product without charge for parts or labor, when returned postage prepaid and insured to INTV Corporation Repair Center, Los Angeles: 3541 B Lomita Blvd., Torrance, CA 90505, with proof of the date of purchase. INTV Corporation reserves the right to utilize reconditioned parts in repairing the product or to utilize reconditioned units (carrying this same 60-Day Limited Warranty) in replacing the product.

This warranty does not apply if the product has been altered or repaired by anyone other than INTV Corporation Repair Center or has been subjected to purchaser abuse, accident, negligence, or damage subsequent to purchase.

Please read the Owner's Manual carefully before using the product. If a malfunction occurs, please refer to the trouble-shooting checklist in the Owner's Manual. If you cannot correct the malfunction after consulting the trouble-shooting checklist, please call the INTV Corporation Repair Center at the numbers shown below.

Units returned without proof of the date-of-purchase, or units returned after the 60-day warranty period has expired, will be repaired or replaced (at our option) for a service charge. Call the following telephone number for the amount of the service charge: (800) 421-2326. Payments must be made by check or money order payable to INTV Corporation. All non-warranty units must be returned postage prepaid and insured with a check or money order in the amount of the service charge to INTV Corporation Repair Center, Los Angeles: 3541 B Lomita Blvd., Torrance, CA 90505.

This warranty excludes incidental or consequential damages resulting from the product or use of the product. (Some states do not allow the exclusion of incidental or consequential damages, so the above exclusion may not apply to you.)

This warranty gives you specific legal rights, and you may also have other rights that vary from state to state. **WARRANTY VALID ONLY IN U.S.A..**

IF YOU NEED SERVICE FROM INTV CORPORATION REPAIR CENTRE . . .

It's available during and after the 60-day warranty period.

1. **Pack** the product carefully in its original box. If the box is not available, use a strong carton with plenty of newspaper or other padding. Enclose a brief note telling us the specific problem you are having with the unit, **and your name and home address.**

2. **Print** this address on the box:

INTV CORPORATION

3541 B Lomita Blvd., Torrance, CA 90505

...and your return address.

3. **Send** the package by U.P.S. or insured parcel post. During the warranty period, enclose proof of purchase date. After warranty has expired, enclose check or money order for the amount quoted by the operator.

NOTICE TO PROJECTION TV OWNERS
Operating the Master Component for extended periods of time on a projection TV system, may cause the Stationary game objects to become permanently imprinted on the projection TV picture tube(s). This is especially true when brightness and contrast controls are set extremely high for game viewing. Observing the following procedures will greatly minimize the chances of a game image being retained on the screen.

1. Always use lowest possible brightness and contrast control settings during game operation.
2. Games containing stationary white or light colored objects should not be played for extended periods of time.
3. Follow your projection TV owners manual for proper viewing conditions for TV games as well as regular TV programming.

CUSTOMER REGISTRATION

Name _____

Address _____

City _____ STATE _____ Zip _____

Telephone _____

Following questions are optional, but they will help us come up with products catered to you and your families interest:

Would you be interested in a weekly TV, movie guide devoted specifically to your child's healthy entertainment?

Yes No

My childrens ages:

We own: House _____ VCR _____

Personal Computer _____ Brand : _____

Occupation: _____ Spouse's Occupation: _____

I HANK YOU!

PRINTED IN HONG KONG WC-2052-2

CUSTOMER
RESPONSE CARD

Place
Postage
Stamp
Here

INTV
21535 Hawthorne Blvd.
Suite 223
Torrance, CA 90503

Return this card for free **INTV** color catalog.