

CANADIAN
POSTAGE
REQUIRED

GAME WAVE

A Division of ZAPiT Games Inc.

P.O. Box 239
Mississauga, Ontario
Canada L4T 3B6



INSTRUCTION MANUAL

www.playgamewave.com



GAME WAVE PLAYER

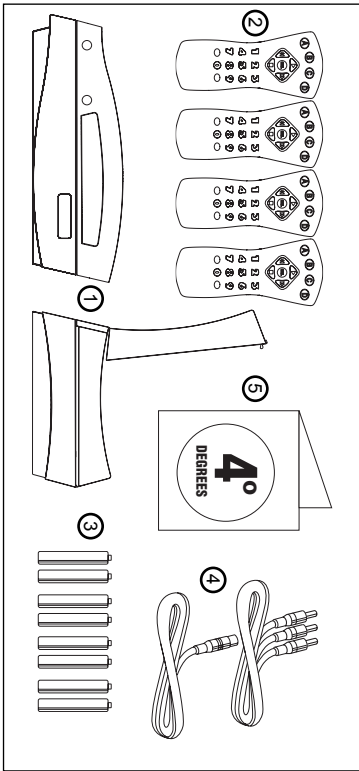

INCLUDES EVERYTHING YOU NEED TO PLAY:

1. Game Wave Player and Remote Control Dock
2. Four Game Wave Wireless Remotes
3. 8 AAA Batteries (2 for each remote)
4. AV Cables and S Video Cable
5. 4 Degrees Trivia Game

PLEASE KEEP THESE INSTRUCTIONS

If you have any questions - visit www.playgamewave.com or call 1-866-562-5144

IMPORTANT

This device complies with Part 15 of the FCC rules. Operation is subject to the following two conditions: (1) This device may cause harmful interference, and (2) this device must accept any interference received, including interference that may cause undesirable operation.

Note: This equipment has been tested and found to comply with the limits for a Class B digital device, pursuant to Part 15 of the FCC rules. These limits are designed to provide reasonable protection against harmful interference in a residential installation. This equipment generates uses and can radiate radio frequency energy and, if not installed and used in accordance with these instructions may cause harmful interference to radio communications. There is no guarantee that interference will not occur in a particular installation. If this equipment does cause harmful interference to radio or television reception, which can be determined by turning the equipment off and on, the user is encouraged to try to correct the interference by one or more of the following measures.

- Increase the separation between equipment and receiver.
- Connect the equipment into an outlet on a circuit different from that to which the receiver is connected.
- Consult the dealer or an experienced radio/TV technician for help.

Product Registration



A Division of ZAPiT Games Inc.

Name _____

Address _____

City _____ State/Prov. _____ Zip/ Postal Code _____

Phone _____ Fax _____

E-Mail Address _____

Please send me News and Updates Yes

Product Purchased _____ Serial Number(s) _____

Purchase Date _____ Where were they purchased? _____ City/State/Prov. _____

We respect your privacy and information is confidential and will not be sold or shared with a third party.

Please register on our website at www.playgamewave.com for faster service.

WARRANTY

We at **ZAPIT Games** believe you will be pleased with your new **Game Wave** system. Please read this warranty carefully. **ZAPIT Games** warrants the **Game Wave** system and remote controls to be free from manufacturing defects including original parts and workmanship for a period of 90 days from the date of original purchase in and if used in Canada and the United States. Should you find your unit not operating properly during the terms of full coverage of this warranty (90 days), **ZAPIT Games** will provide one of the following options (at **ZAPIT Games'** discretion) providing that the manufacturing defect is verified along with date of purchase:

Repair or replacement of your defective system with either a new, refurbished or equivalent model for 90 days from the date of original purchase at no charge for labor and parts.

CUSTOMER OBLIGATIONS

The warranty applies to the product from the original date of purchase at retail or online. Therefore, the owner must provide a copy of the original, dated bill of sale. No warranty service will be performed without a bill of sale.

The warranty is void if the product is:

- A) Damaged through negligence, abuse, misuse, accident, or acts of God.
- B) Used in commercial applications or rentals.
- C) Modified or repaired by anyone other than **ZAPIT Games** or their authorized representative.
- D) Damage resulting from the improper connection to equipment of other manufacturers.

This warranty does not cover:

- A) Cost incurred in the shipping of the product to and from the **ZAPIT Games** repair facility.
- B) Damage or improper operation caused by the failure to follow the operating instructions provided with the product.
- C) Routine adjustments to the product which can be performed by the customer as outlined in this manual.
- D) Damage to DVD movies and Game discs.
- E) Signal reception problems caused by external forces.
- F) Products purchased outside of Canada and the United States.
- G) Damage to the products used outside of Canada and the United States.

THIS WARRANTY is non-transferable and applies solely to the original purchaser and does not extend to subsequent owners of the product. Any applicable implied warranties, including the warranty of merchantability, are limited in duration to a period of the expressed warranty as provided herein beginning with the date of the original purchase at retail and no warranties, whether expressed or implied shall apply to the product thereafter. **ZAPIT Games** makes no warranty as to the fitness of the product for any particular purpose or use. The extent of **ZAPIT Games'** liability under this warranty is the repair or replacement provided above at the sole discretion of **ZAPIT Games** and in no event shall **ZAPIT Games** liability exceed the purchase price paid by the purchaser. Under no circumstances shall **ZAPIT Games** be liable for any loss, direct, indirect, incidental, foreseen, unforeseen, special or consequential damage arising out of or in connection with the use of this product. This warranty is only valid in Canada and the US. This warranty gives you specific legal rights. However, you may have other rights which may vary from province to province and state to state. Some provinces and/or states do not allow limitations on implied warranties or exclusion of consequential damage, therefore these restrictions may not apply to you.

IMPORTANT SAFETY INFORMATION

The exclamation point within an equilateral triangle is intended to alert the user to the presence of important operating and maintenance instructions in the literature accompanying the appliance.



CAUTION
RISK OF ELECTRIC SHOCK
DO NOT OPEN



The lightning flash with an equilateral triangle, is intended to alert the user to the presence of uninsulated "dangerous voltage" within the product's enclosure that may be of sufficient magnitude to constitute a risk of electric shock to persons.

AVIS RISQUE DE CHOC ELECTRIQUE / NE PAS OUVRIR

TO REDUCE THE RISK OF SERIOUS INJURY OR DEATH, OR DAMAGE TO THE GAME WAVE UNIT: READ ALL INSTRUCTIONS. KEEP THESE INSTRUCTIONS. HEED ALL WARNINGS. FOLLOW ALL INSTRUCTIONS.

WARNING

To prevent fire or shock hazard, do not expose this appliance to rain or moisture. Clean only with a dry cloth. The equipment should not be exposed to dripping or splashing and no objects filled with liquids, such as vases should be placed on device. The ventilation should not be impeded by covering the ventilation openings with items, such as newspapers, tablecloths, curtains, etc.

CAUTION

TO PREVENT ELECTRIC SHOCK, DO NOT USE THIS (POLARIZED) PLUG WITH ANY EXTENSION CORD, RECEPTACLE OR OTHER OUTLET UNLESS PLUG CAN BE FULLY INSERTED WITHOUT EXPOSING ANY PARTS OF THE BLADES.

Do not take the Game Wave apart or attempt to service it yourself. Servicing is required when the device has been damaged in any way such as: 1) Power Supply cord or plug has been damaged. 2) Liquid has been spilled or objects have fallen into

device. 3) Device has been exposed to rain, moisture or has been dropped.

The device should be situated so its location or position does not interfere with its proper ventilation. It should not be placed near heat sources including radiators, heat registers, stoves, etc.

Power supply cords should be routed so that they are not likely to be walked on or pinched by items placed upon or against them, paying special attention to cords at plugs, convenience receptacles, and the point where they exit from the appliance.

Only use attachments/accessories specified by the manufacturer.

Power cord should be unplugged from the outlet when left unused for a long period of time or during lightning storms.

If the Game Wave falls and hits someone, especially a small child, it could cause serious injury. To reduce risk of such injuries or damage to the device, set the device on a flat surface.

Always unplug the Game Wave from the power outlet before connecting or disconnecting from a TV, VCR, or other AVV device.

CONNECTING TO TV/VCR

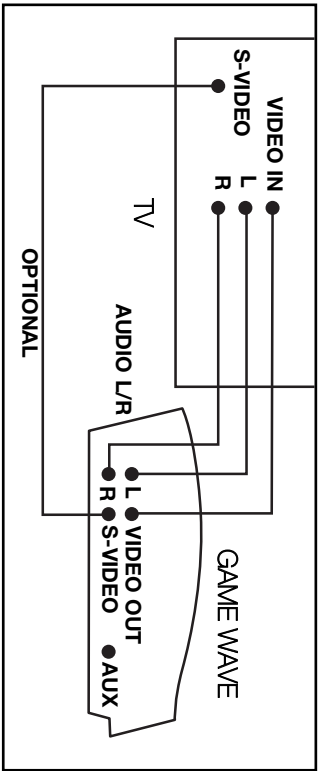

TO CONNECT TO TV

1. Make sure the Game Wave is unplugged from the power outlet.
2. Connect the corresponding color coded jacks on both the Game Wave and TV. Yellow to yellow (video), red to red (right audio) and white to white (left audio).

Note: For monaural TV's which have only one audio jack, connect either the right or left audio connector to the audio jack.

3. Plug the Game Wave into the power outlet.
4. Select the appropriate video input on TV.

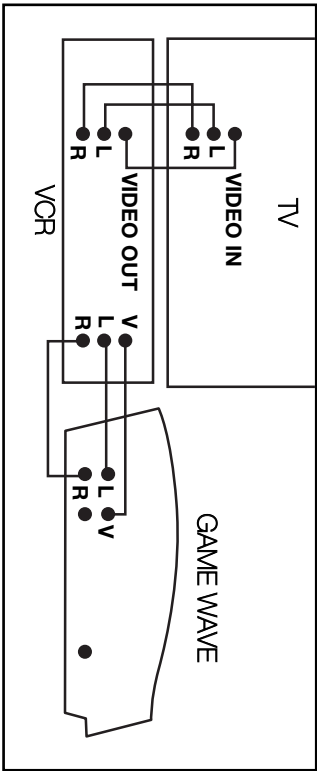

TO CONNECT TO A VCR

1. Make sure the Game Wave is unplugged from the power outlet.
2. Connect the corresponding color coded jacks on both the Game Wave and VCR. Yellow to yellow (video), red to red (right audio) and white to white (left audio).

Note: For monaural VCR's, connect either the right or left audio connector to the audio jack.

3. Plug the Game Wave into the power outlet and select VCR for TV/VCR setting.
4. Select the appropriate video input on TV.

TROUBLESHOOTING (cont.)

SYMPTOM	CAUSE	CORRECTION
The disc tray does not open when OPEN/CLOSE button is pressed	The Game Wave is not ready to open	The OPEN/CLOSE button is not operational until the system has completely started up. This takes about 5 seconds from the time you turn it on. Please wait a full 5 seconds after turning the Game Wave on before attempting to use the OPEN/CLOSE button

THIS INSTRUCTION BOOK MAY CONTAIN ERRORS AND OMISSIONS. ALL ASPECTS DESCRIBED ARE SUBJECT TO CHANGE WITHOUT NOTICE.

Game Wave, the Game Wave design and the Game Wave logo are trademarks of ZAPT Games Inc. All rights reserved.

ZAPT GAMES INC.

MISSISSAUGA, ONTARIO
L5T 2K9
Toll Free: 1-866-562-5144
www.playgamewave.com

PRODUCT SPECIFICATIONS

GENERAL	
Power Source	AC 120V/240V 50-60HZ
Power Consumption	20W
Mass (approximate)	2350 g
External Dimensions	17" x 10 1/2" x 3"
Operating Conditions	Temperature- 5°C - 35°C (41°F - 95°F)

This Class B digital apparatus complies with Canadian ICES-003

Design and specifications are subject to change without notice.

TROUBLESHOOTING

SYMPTOM	CAUSE	CORRECTION
The power is on, but Game Wave does not work	No disc is inserted	Insert a disc
No picture	The TV is not set to receive the signal output from the Game Wave	Select the appropriate video input mode on the TV so the picture appears on the screen
	The video cable is not connected properly to the TV or Game Wave	Make sure the yellow AV cable or S-Video cable is connected securely to the correct jack on the TV or Game Wave
No sound	The equipment connected with the audio cable is not set to receive the signal output Volume is low or muted The audio cable is not connected properly	Set your audio receiver to the correct input mode so that sound can be heard Turn volume up Make sure the red and white audio cables are connected to the red and white jacks securely
The picture is poor or flickers	The disc is dirty The video cable is not connected securely to the TV or Game Wave	Clean the disc Make sure the yellow AV cable or S-Video cable is connected securely to the TV or Game Wave
The Game Wave will not play movies or games	No disc is inserted An unplayable disc is inserted The disc is inserted upside down The disc is dirty or scratched	Insert a disc Insert a playable disc (Check the disc type, color system, and Regional Code) Make sure the disc is inserted with the label facing up Make sure the disc is clean and not scratched
The remote control does not work properly	The remote control is too far from the Game Wave player There is an obstacle in the path of the remote and the Game Wave player The batteries in the remote control are exhausted	Use the remote within approx. 12 feet of the Game Wave Make sure there is a clear path between the remote and the front of the Game Wave Player Replace the batteries

USING GAME WAVE PLAYER

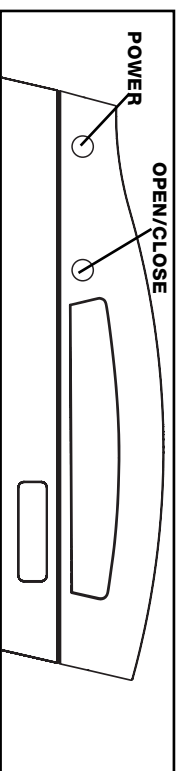

1. Make sure that all connections to the TV, VCR, or other AV devices are complete.
2. Turn on the Game Wave by pressing the power button.
3. When finished, turn off the Game Wave by pressing the power button. To eliminate all voltage inside the unit, turn off the Game Wave and then unplug the power cord from the power outlet.

LOADING BATTERIES IN REMOTE CONTROLS

1. Remove battery cover on back of remote.
2. Insert two AAA batteries, making sure the polarity (+/-) matches the marks inside the remote.
3. Replace the cover. Do not attempt to recharge, short circuit, disassemble, heat or throw the batteries in a fire. Do not mix old and new batteries. Dispose of batteries properly in accordance with local law.

Note: Old or weak batteries can leak and severely damage the remote control units.

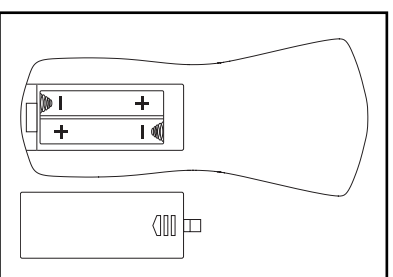

PLAYING GAME WAVE GAMES

The Game Wave can only play games with the Game Wave logo on them.

To start a game

1. Press the OPEN/CLOSE button to open the disc tray.
2. Place the game disc seated level in the disc tray with the label facing up.
3. Press the OPEN/CLOSE button to close the disc tray. After a brief pause the game will start.

To end a game

1. Press the OPEN/CLOSE button to open the disc tray.
2. Remove the game disc.
3. Press the OPEN/CLOSE button to close the disc tray.

* Turn off Game Wave when not in use.

PLAYING DVDS

Any one of the Game Wave remote controls can be used for controlling DVD playback. While viewing a DVD, use the arrow keys to **play/pause**, **fast forward**, **fast rewind** or **stop** the movie.

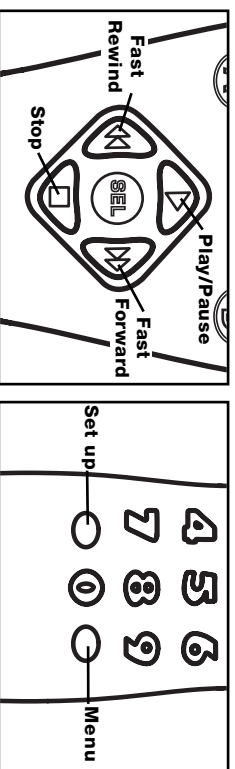

ON-SCREEN DVD CONTROLS

At any time during DVD playback, the on-screen controls can be used for operations not found on the remote control. Pressing the **MENU** button on the remote activates the on-screen controls. Use the left and right arrow keys to scroll through the on-screen controls; as different control buttons are highlighted on screen, the name of that particular function is displayed below the running time indicator. Once the desired function is highlighted, press **SEL** to perform it. Use the "**close**" function or press the **MENU** button on the remote to close the on-screen controls.

Note: While the on-screen control menu is displayed, the arrow buttons cannot be pressed to play/pause, fast forward, rewind or stop directly. Select the desired function from the menu or press **MENU** to return to normal operation.

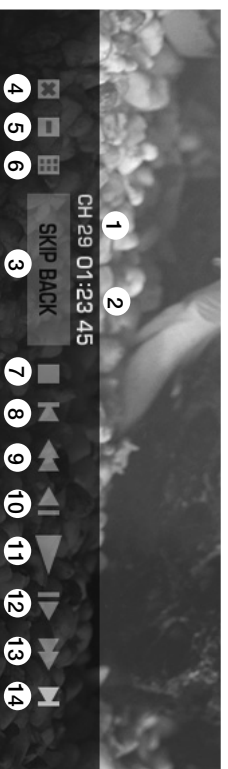

On-Screen DVD Controls Menu (Bottom of TV Screen)

1. Current chapter
2. Running time
3. Currently selected function
4. Close on screen DVD controls
5. Title
6. Menu
7. Stop
8. Skip back to previous chapter
9. Fast rewind
10. Slow rewind
11. Play / Pause
12. Slow forward
13. Fast forward
14. Skip ahead to next chapter

SYSTEM SET-UP MENU

At any time during movie playback or when the Game Wave is idle, the system setup menu can be activated by pressing the **SETUP** button on any remote. The setup menu allows you to change various movie playback and game memory options. The different setup menus and options can be navigated using the up/down/left/right arrow buttons on any of the remotes.

MOVIE SETTINGS MENU

Viewing Mode

Allows you to adjust movie playback based on your television.

Normal - This setting is for standard 4:3 televisions. This is the default setting.

Widescreen - This setting is for widescreen 16:9 televisions.

Movie Settings Menu



Audio Language and Menu Language

Adjusts the default language for movie audio and the main menu of the disc.

Note: Adjusting language settings will only work if your movie disc features multiple languages.

Audio Language Set-up



SYSTEM MEMORY MENU

All of the Game Wave saved games are listed here and can be deleted. Use the up and down buttons on the remote to highlight the saved game and press the **SEL** button to delete it. To delete all saved games press the "0" button and memory will be formatted.

Note: Deleting a saved game means that you will have to re-play that game from the start.

System Memory Menu

